

# Essential

Awning Window (52mm)

Casement Window (52mm)

Fixed Window (52mm-EG)

## Installation Details

BRICK VENEER CONSTRUCTION - SILL & JAMB DETAIL

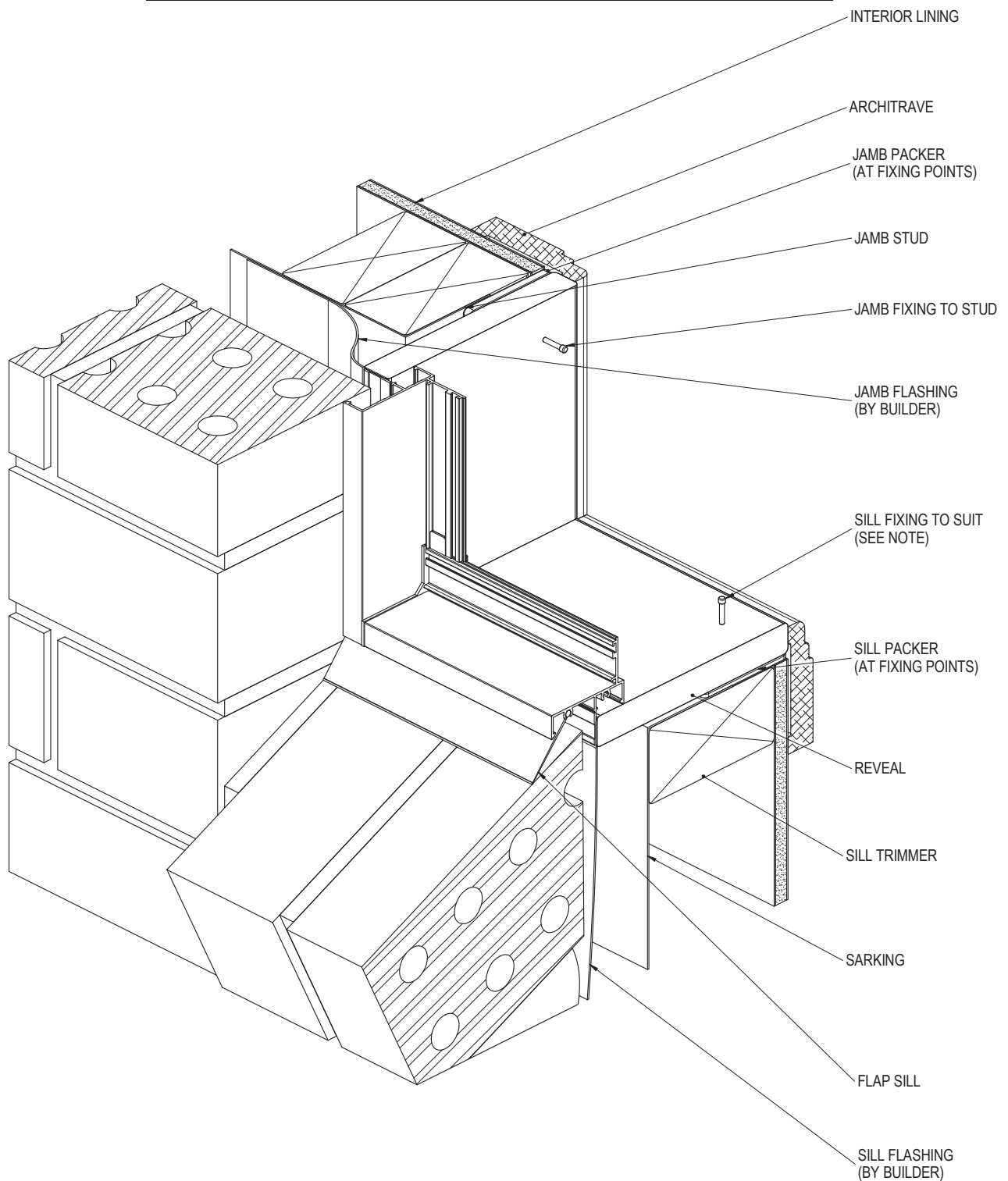

NOTE:  
FOR SITE CLASSIFICATIONS OF UP TO AND INCLUDING 'N6' OR SIMILAR, FIXINGS ARE TO BE AT 450mm CENTRE MAXIMUM, FOR SITUATIONS IN EXCESS OF THIS THE FIXINGS ARE TO BE AT 300mm CENTRES MAXIMUM. FIXING SIZE TO BE EQUIVALENT TO A  $\phi$ 2.2mm STEEL NAIL MINIMUM.

PRODUCT NO: ESS-AWN-52

DATE: 20/05/14

DRAWING NO: ESS-AWN-02-01

ISSUE: A

DRAWN: JCF

SCALE: 1 : 3

**BRICK VENEER CONSTRUCTION - HEAD & JAMB DETAIL**

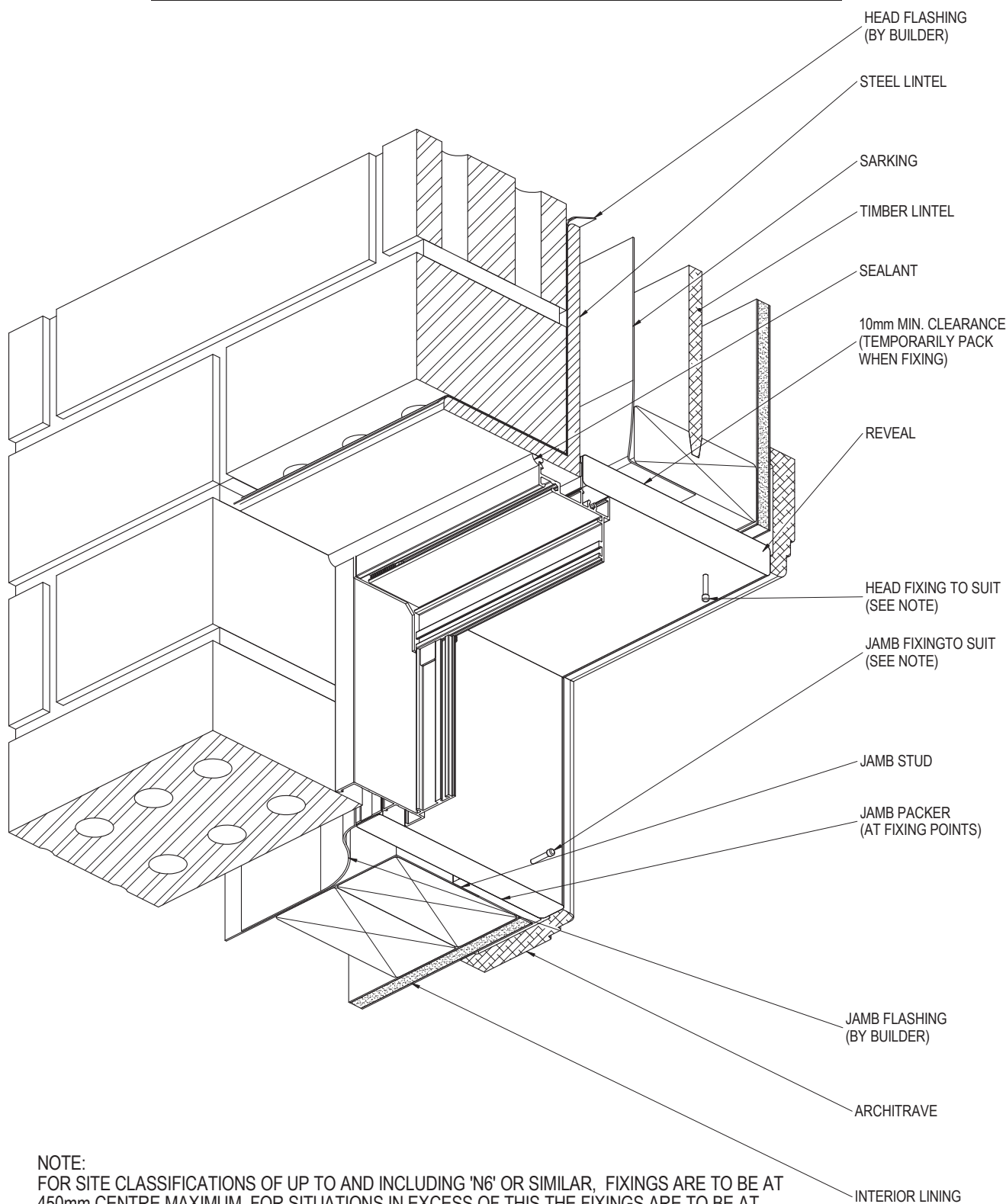

NOTE:  
 FOR SITE CLASSIFICATIONS OF UP TO AND INCLUDING 'N6' OR SIMILAR, FIXINGS ARE TO BE AT 450mm CENTRE MAXIMUM, FOR SITUATIONS IN EXCESS OF THIS THE FIXINGS ARE TO BE AT 300mm CENTRES MAXIMUM. FIXING SIZE TO BE EQUIVALENT TO A  $\varnothing$ 2.2mm STEEL NAIL MINIMUM.

PRODUCT NO: ESS-AWN-52

DATE: 20/05/14

DRAWING NO: ESS-AWN-02-02

ISSUE: A

DRAWN: JCF

SCALE: 1 : 3

CLADDING CONSTRUCTION - SILL & JAMB DETAIL

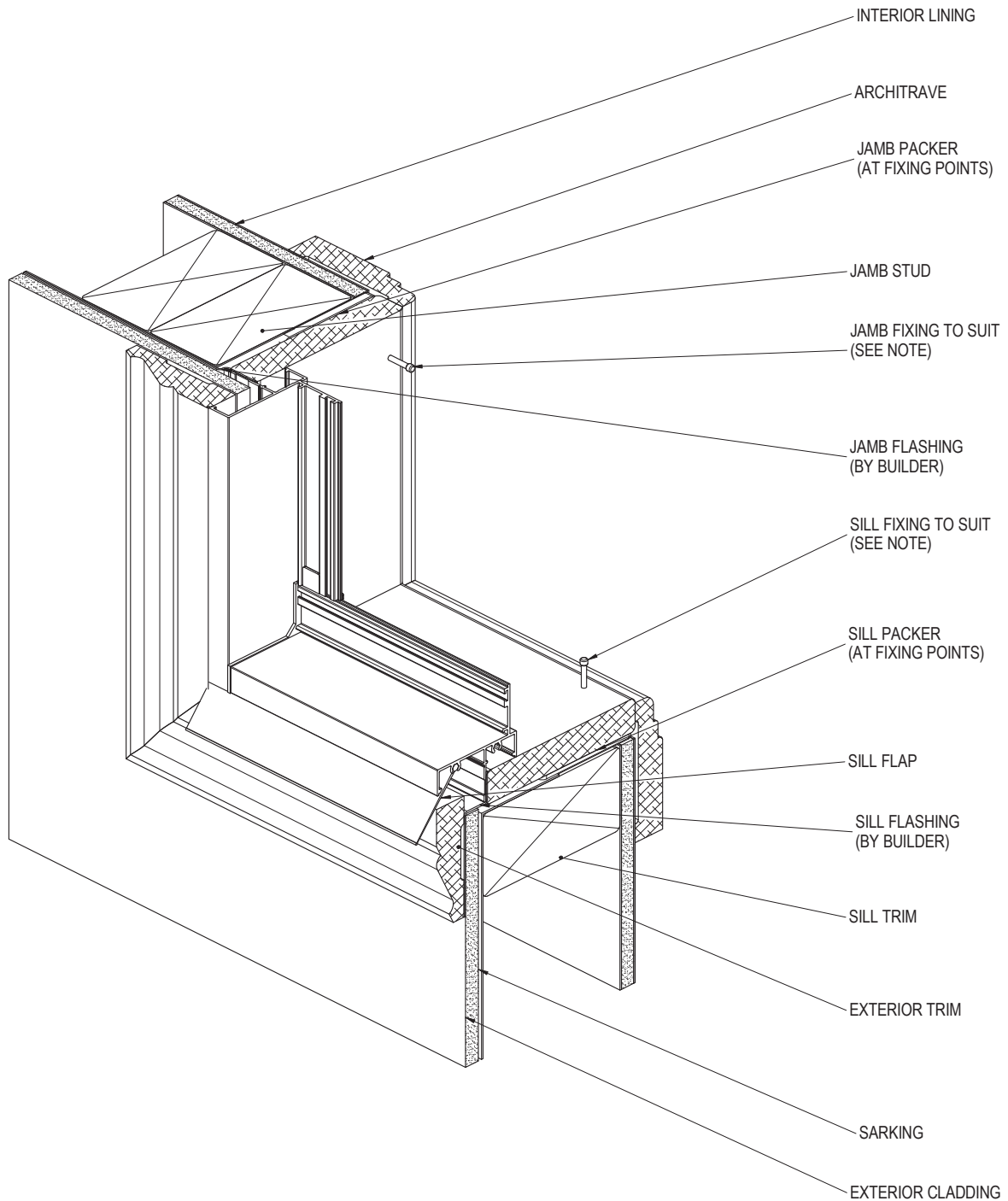

NOTE:  
 FOR SITE CLASSIFICATIONS OF UP TO AND INCLUDING 'N6' OR SIMILAR, FIXINGS ARE TO BE AT 450mm CENTRE MAXIMUM, FOR SITUATIONS IN EXCESS OF THIS THE FIXINGS ARE TO BE AT 300mm CENTRES MAXIMUM. FIXING SIZE TO BE EQUIVALENT TO A  $\varnothing$  2.2mm STEEL NAIL MINIMUM.

PRODUCT NO: ESS-AWN-52

DATE: 20/05/14

DRAWING NO: ESS-AWN-02-03

ISSUE: A

DRAWN: JCF

SCALE: 1 : 3

CLADDING CONSTRUCTION - HEAD & JAMB DETAIL

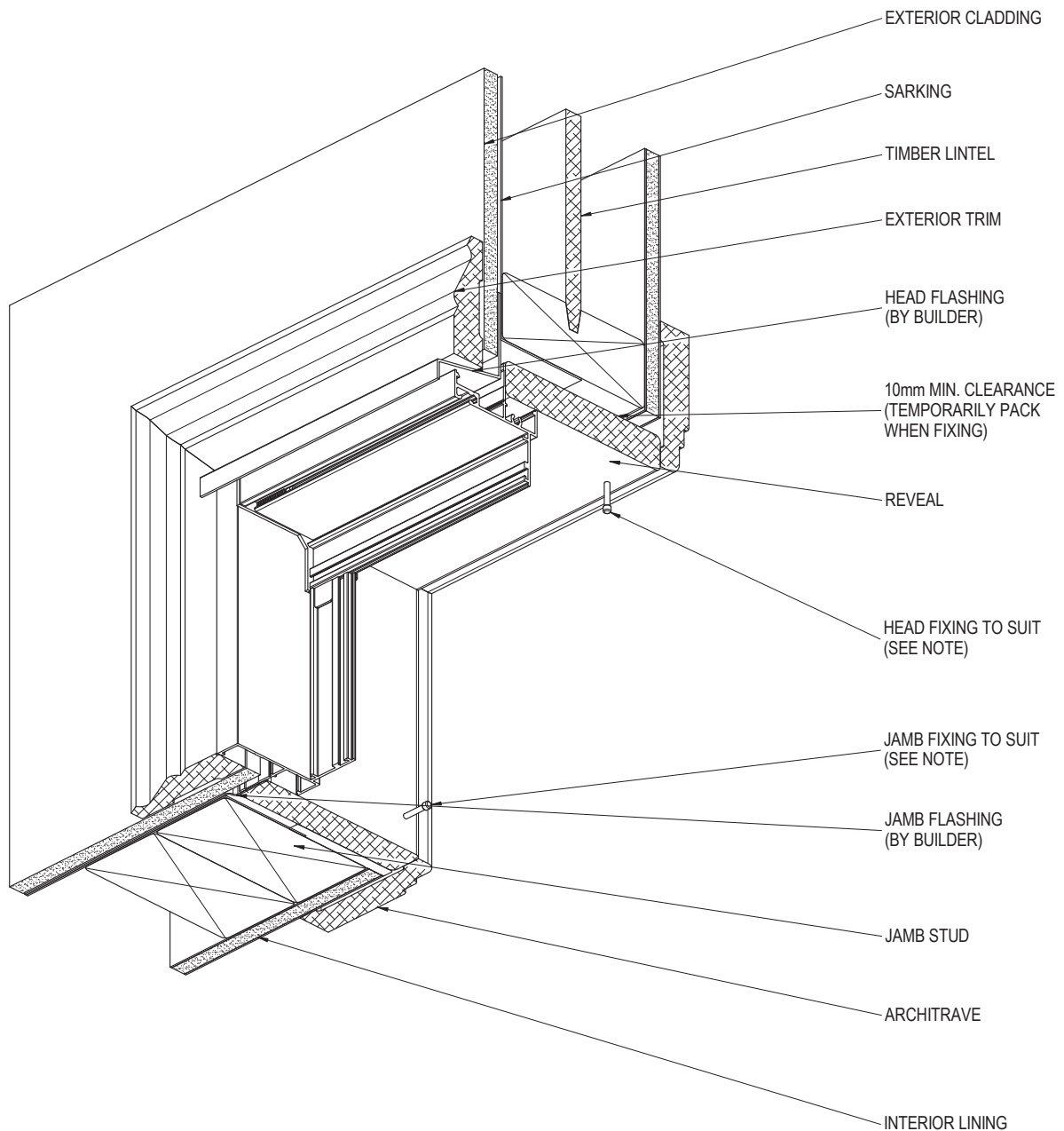

NOTE:  
FOR SITE CLASSIFICATIONS OF UP TO AND INCLUDING 'N6' OR SIMILAR, FIXINGS ARE TO BE AT 450mm CENTRE MAXIMUM, FOR SITUATIONS IN EXCESS OF THIS THE FIXINGS ARE TO BE AT 300mm CENTRES MAXIMUM. FIXING SIZE TO BE EQUIVALENT TO A  $\phi$  2.2mm STEEL NAIL MINIMUM.

PRODUCT NO: ESS-AWN-52

DATE: 20/05/14

DRAWING NO: ESS-AWN-02-04

ISSUE: A

DRAWN: JCF

SCALE: 1 : 3

CAVITY BRICK CONSTRUCTION - SILL & JAMB DETAIL

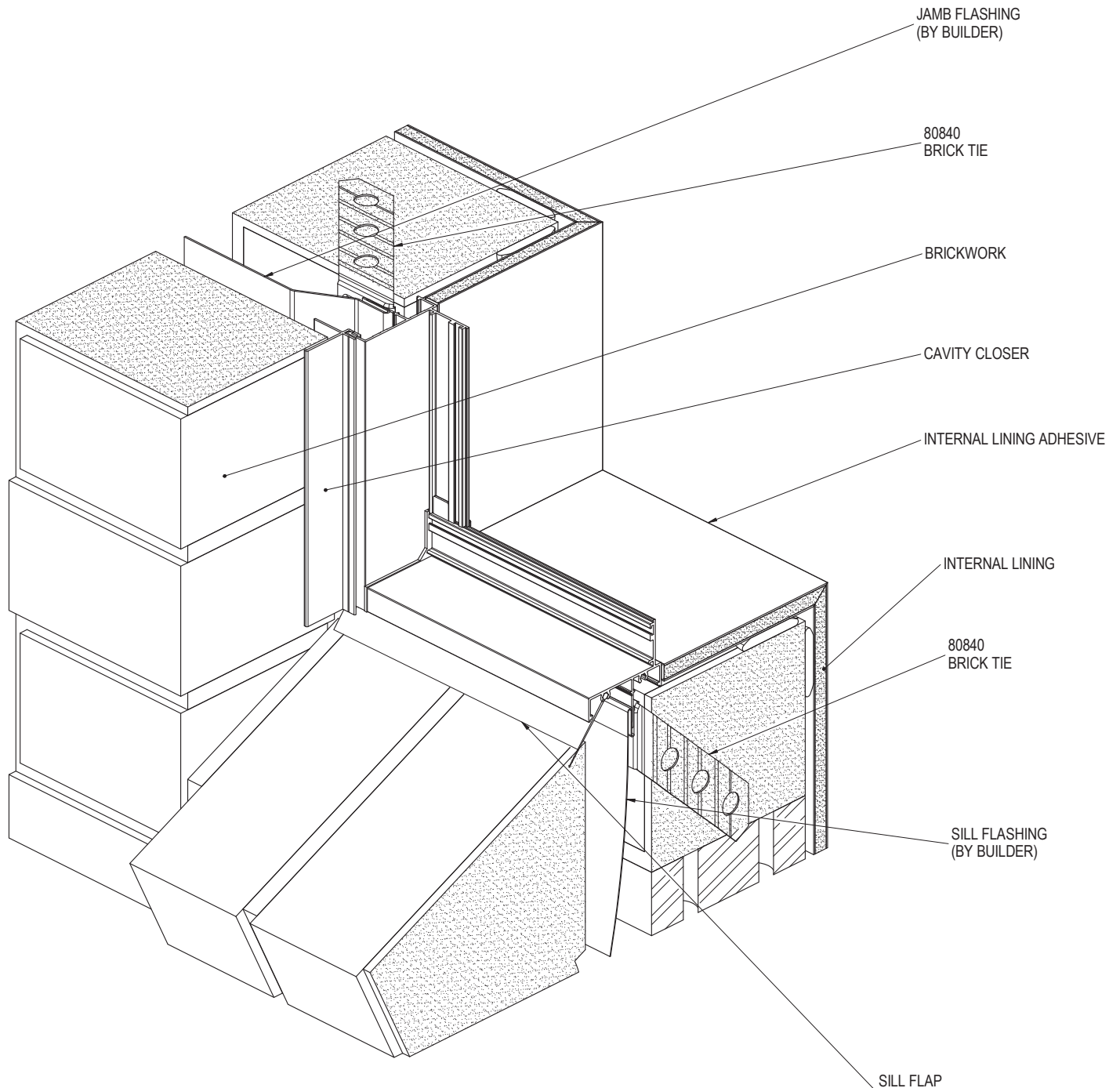

NOTE:  
FOR SITE CLASSIFICATIONS OF UP TO AND INCLUDING 'N6' OR SIMILAR, FIXINGS ARE TO BE AT 450mm CENTRE MAXIMUM, FOR SITUATIONS IN EXCESS OF THIS THE FIXINGS ARE TO BE AT 300mm CENTRES MAXIMUM. FIXING SIZE TO BE EQUIVALENT TO A  $\varnothing 2.2$ mm STEEL NAIL MINIMUM.

PRODUCT NO: ESS-AWN-52

DATE: 20/05/14

DRAWING NO: ESS-AWN-02-05

ISSUE: A

DRAWN: JCF

SCALE: 1 : 3

CAVITY BRICK CONSTRUCTION - HEAD & JAMB DETAIL

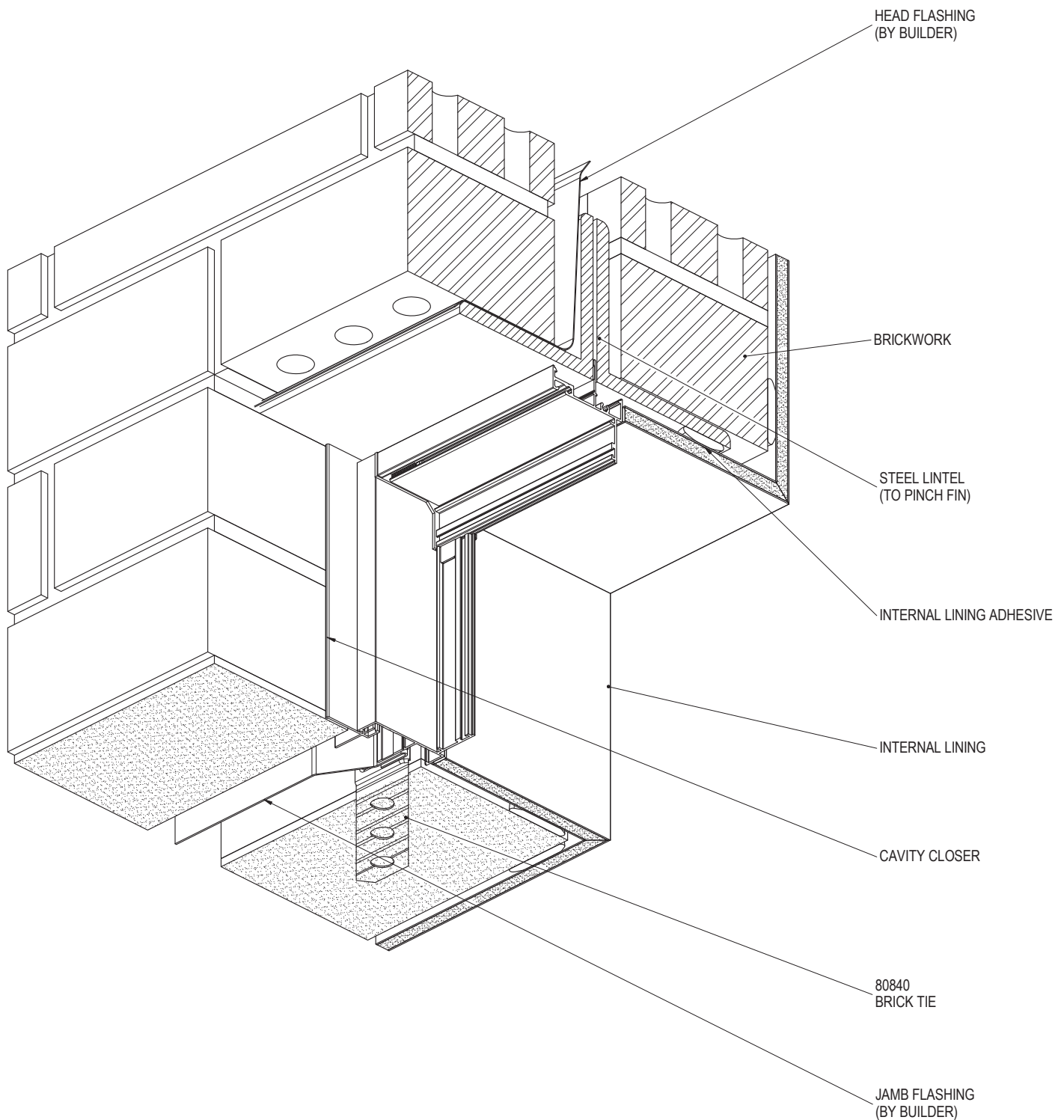

NOTE:  
FOR SITE CLASSIFICATIONS OF UP TO AND INCLUDING 'N6' OR SIMILAR, FIXINGS ARE TO BE AT  
450mm CENTRE MAXIMUM, FOR SITUATIONS IN EXCESS OF THIS THE FIXINGS ARE TO BE AT  
300mm CENTRES MAXIMUM. FIXING SIZE TO BE EQUIVALENT TO A  $\varnothing$ 2.2mm STEEL NAIL MINIMUM.

PRODUCT NO: ESS-AWN-52

DATE: 20/05/14

DRAWING NO: ESS-AWN-02-06

ISSUE: A

DRAWN: JCF

SCALE: 1 : 3

BLOCKWORK CONSTRUCTION - SILL & JAMB DETAIL

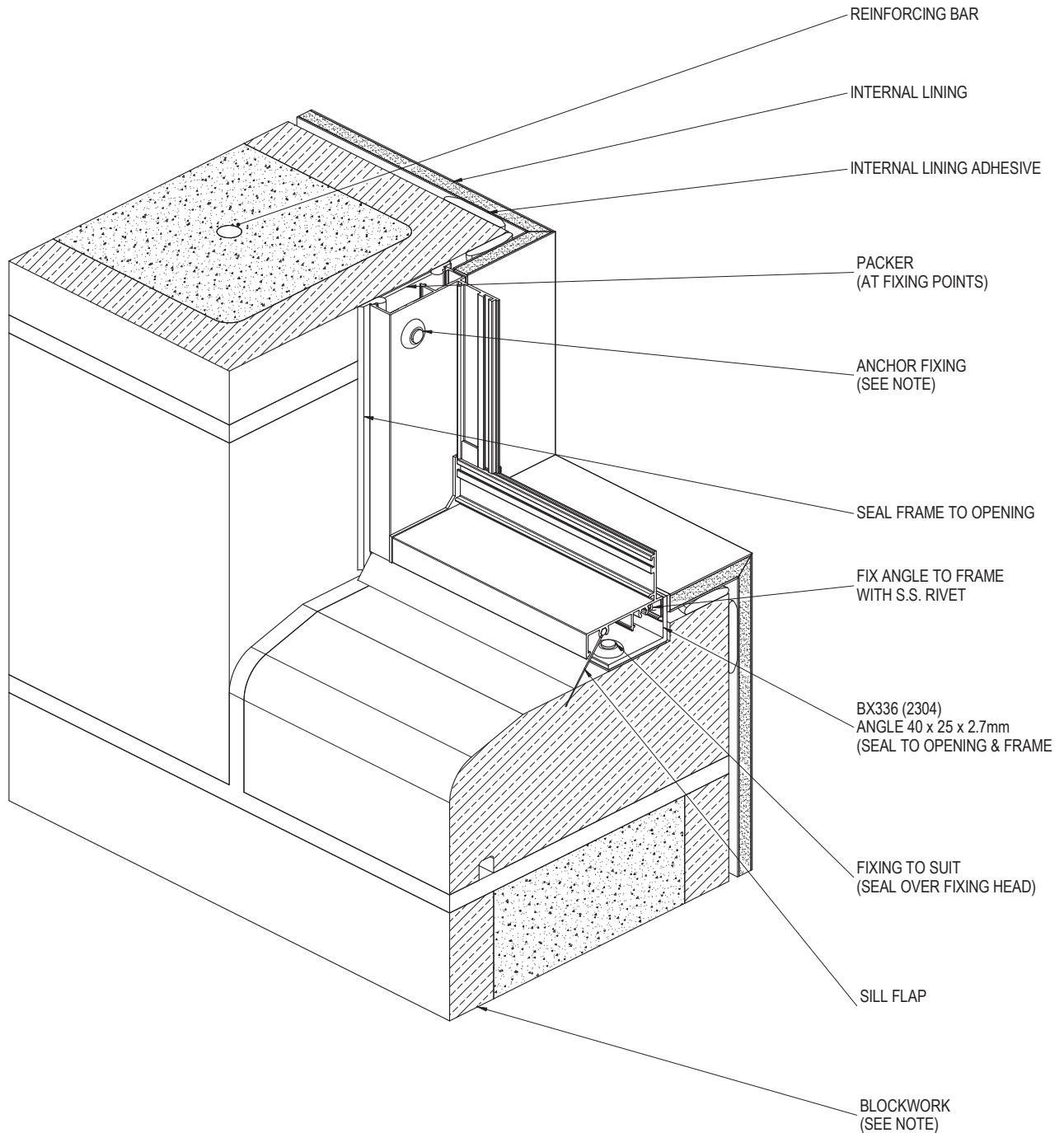

NOTE:  
 SURFACE OF BLOCKS TO WINDOW OPENING MUST BE TANKED WITH A SUITABLE SEALER TO PREVENT INGRESS OF MOISTURE. ENSURE SURFACES TO BE SEALED ARE SOUND, CLEAN, DRY AND FREE FROM ANY CONTAMINANTS BEFORE SEALING.

FOR SITE CLASSIFICATIONS OF UP TO AND INCLUDING 'N6' OR SIMILAR, FIXINGS ARE TO BE AT 450mm CENTRE MAXIMUM, FOR SITUATIONS IN EXCESS OF THIS THE FIXINGS ARE TO BE AT 300mm CENTRES MAXIMUM. FIXING SIZE TO BE EQUIVALENT TO A  $\phi$  2.2mm STEEL NAIL MINIMUM.

PRODUCT NO: ESS-AWN-52

DATE: 21/05/14

DRAWING NO: ESS-AWN-02-07

ISSUE: A

DRAWN: JCF

SCALE: 1 : 3



BLOCKWORK CONSTRUCTION - HEAD & JAMB DETAIL

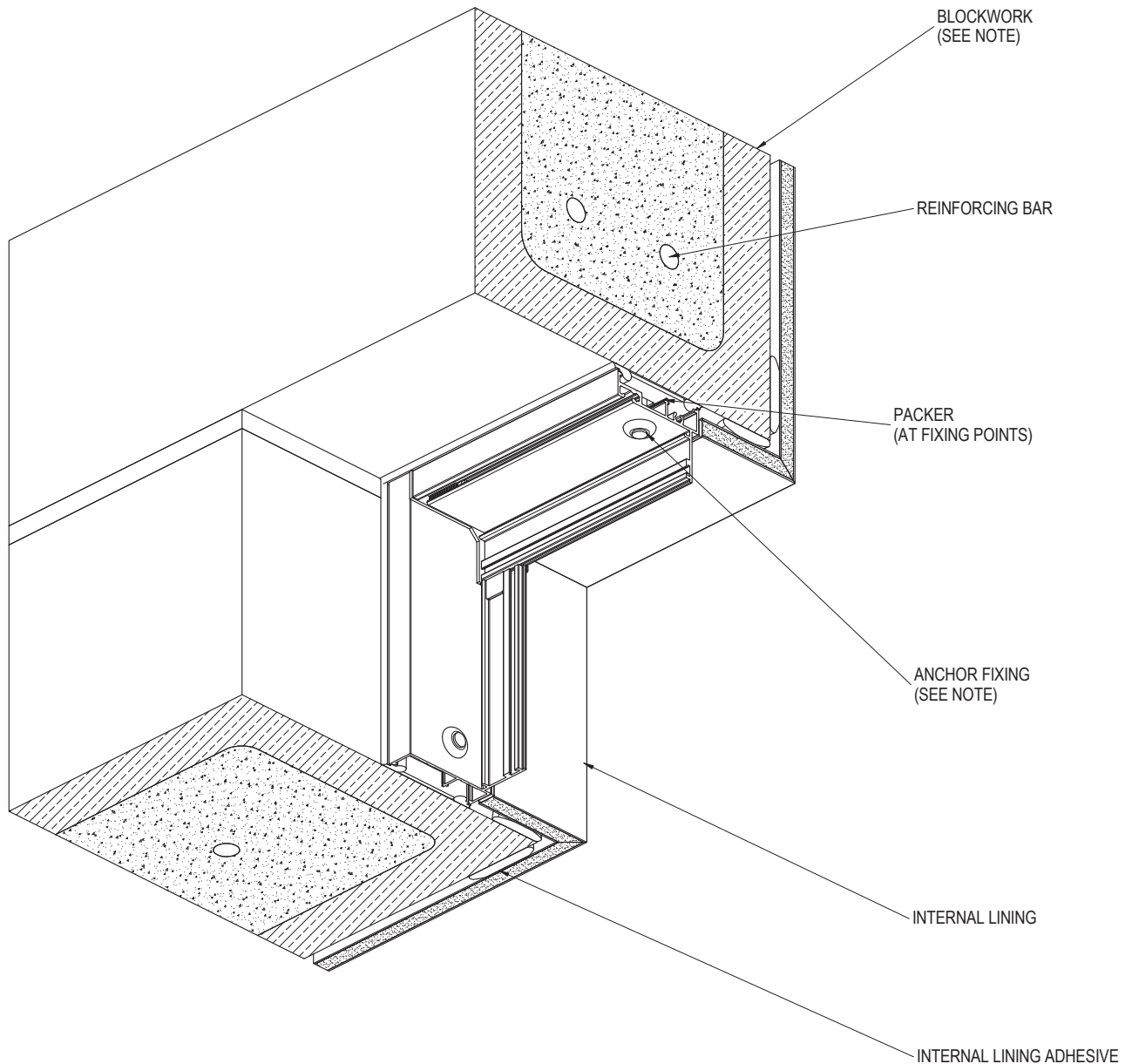

NOTE:  
SURFACE OF BLOCKS TO WINDOW OPENING MUST BE TANKED WITH A SUITABLE SEALER TO PREVENT INGRESS OF MOISTURE. ENSURE SURFACES TO BE SEALED ARE SOUND, CLEAN, DRY AND FREE FROM ANY CONTAMINANTS BEFORE SEALING.

FOR SITE CLASSIFICATIONS OF UP TO AND INCLUDING 'N6' OR SIMILAR, FIXINGS ARE TO BE AT 450mm CENTRE MAXIMUM, FOR SITUATIONS IN EXCESS OF THIS THE FIXINGS ARE TO BE AT 300mm CENTRES MAXIMUM. FIXING SIZE TO BE EQUIVALENT TO A  $\phi$ 2.2mm STEEL NAIL MINIMUM.

PRODUCT NO: ESS-AWN-52

DATE: 22/05/14

DRAWING NO: ESS-AWN-02-08

ISSUE: A

DRAWN: JCF

SCALE: 1 : 3

TILT SLAB CONSTRUCTION - SILL & JAMB DETAIL

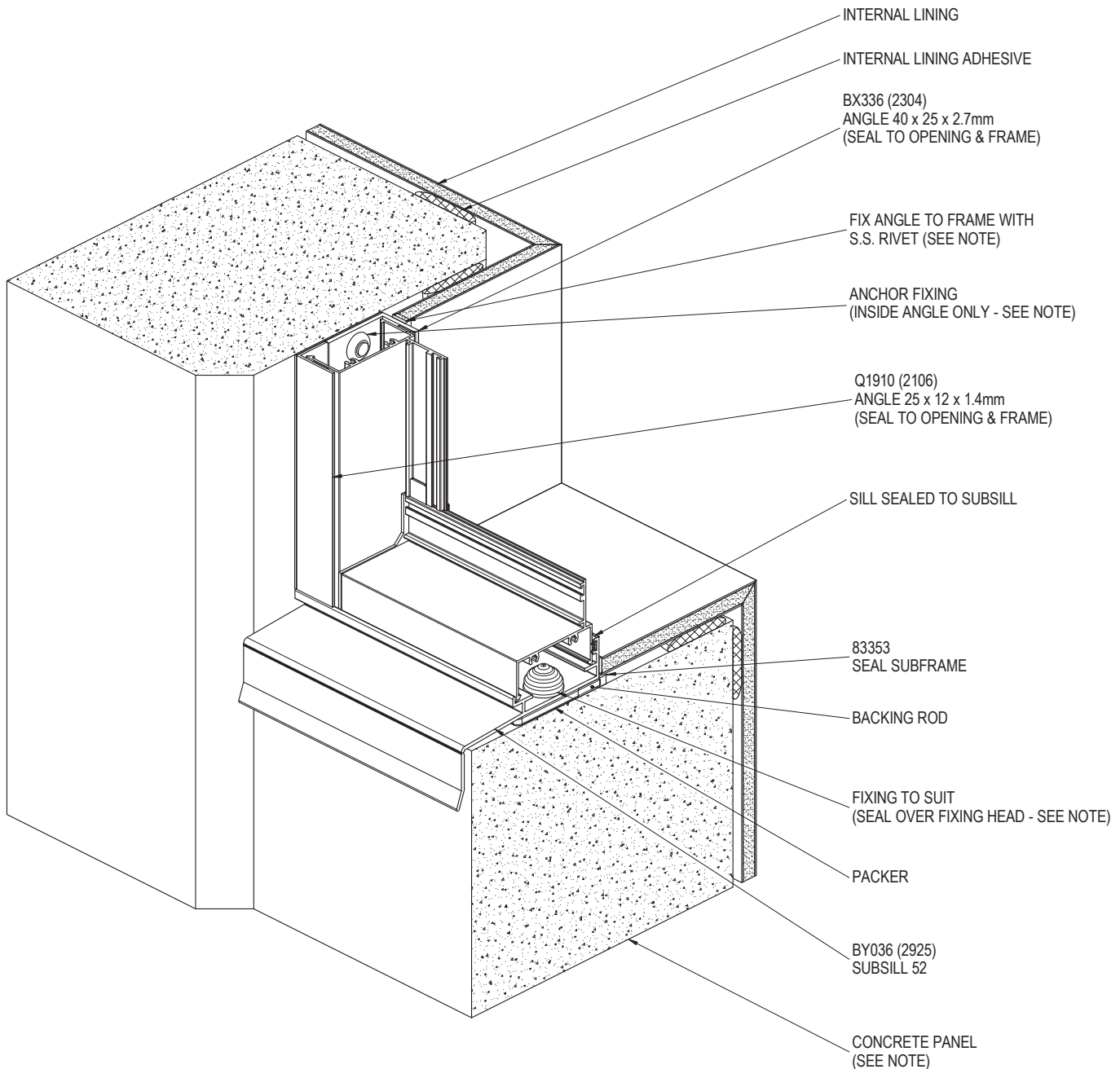

NOTE:  
 SURFACE OF CONCRETE TO WINDOW OPENING MUST BE TANKED WITH A SUITABLE SEALER TO PREVENT INGRESS OF MOISTURE. ENSURE SURFACES TO BE SEALED ARE SOUND, CLEAN, DRY AND FREE FROM ANY CONTAMINANTS BEFORE SEALING.

FIXING TYPES & CENTRES TO BE PROJECT SPECIFIC, REFER TO SPECIFICATION AND/OR ENGINEER.

PRODUCT NO: ESS-AWN-52

DATE: 22/05/14

DRAWING NO: ESS-AWN-02-09

ISSUE: A

DRAWN: JCF

SCALE: 1 : 3



TILT SLAB CONSTRUCTION - HEAD & JAMB DETAIL

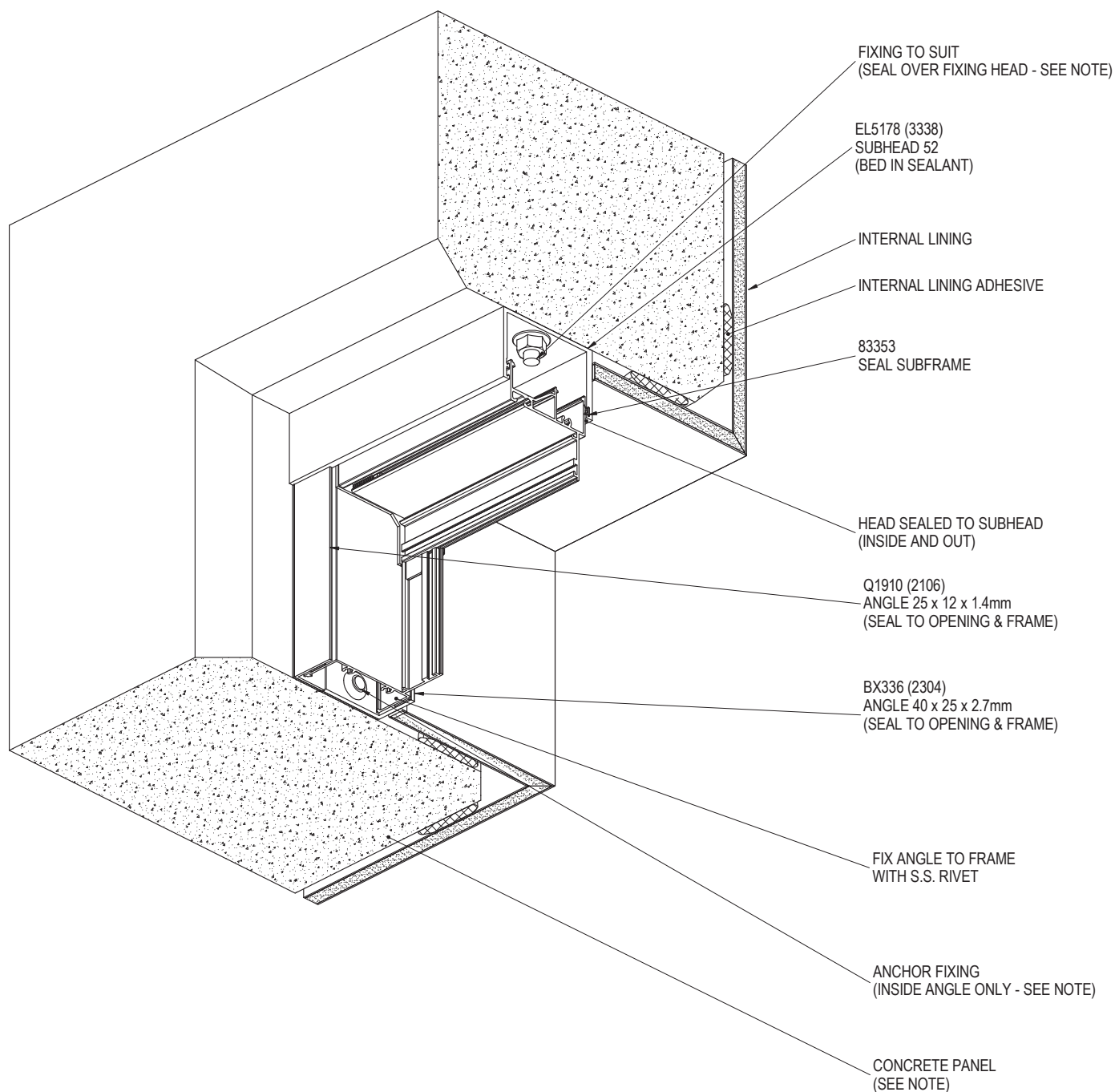

NOTE:  
 SURFACE OF CONCRETE TO WINDOW OPENING MUST BE TANKED WITH A SUITABLE SEALER TO PREVENT INGRESS OF MOISTURE. ENSURE SURFACES TO BE SEALED ARE SOUND, CLEAN, DRY AND FREE FROM ANY CONTAMINANTS BEFORE SEALING.

FIXING TYPES & CENTRES TO BE PROJECT SPECIFIC, REFER TO SPECIFICATION AND/OR ENGINEER.

PRODUCT NO: ESS-AWN-52

DRAWING NO: ESS-AWN-02-10

DRAWN: JCF

DATE: 23/05/14

ISSUE: A

SCALE: 1 : 3

