

Signature

Awning Window TB (100mm)

Casement Window TB (100mm)

Fixed Window TB (100mm – EG)

Installation Details



SUNCOAST
WINDOWS

Quality . Style . Innovation

BRICK VENEER CONSTRUCTION - SILL & JAMB DETAIL

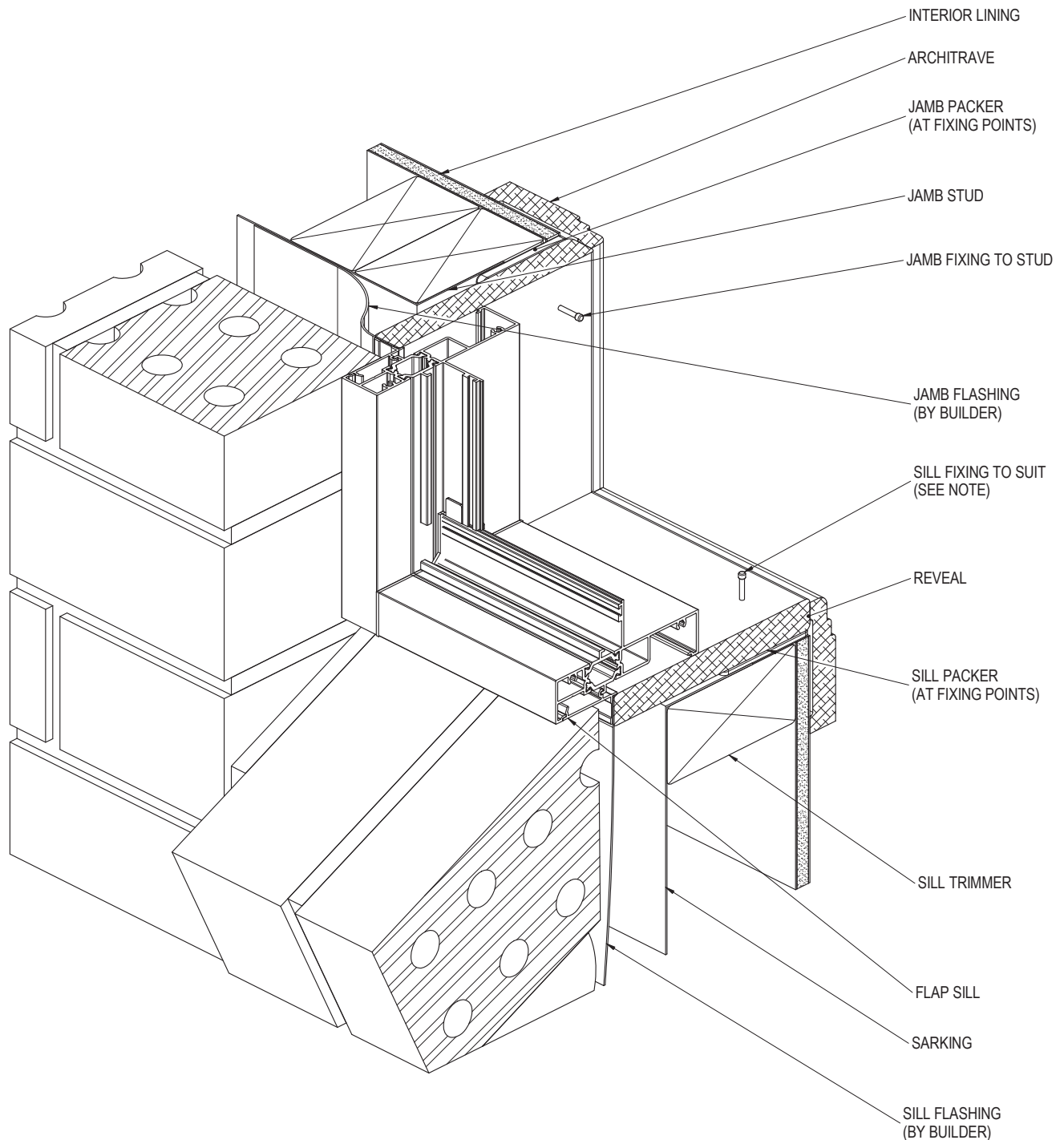

NOTE:
FOR SITE CLASSIFICATIONS OF UP TO AND INCLUDING 'N6' OR SIMILAR, FIXINGS ARE TO BE AT 450mm CENTRE MAXIMUM, FOR SITUATIONS IN EXCESS OF THIS THE FIXINGS ARE TO BE AT 300mm CENTRES MAXIMUM. FIXING SIZE TO BE EQUIVALENT TO A \varnothing 2.2mm STEEL NAIL MINIMUM.

PRODUCT NO: TB-AWN-100
DRAWING NO: TB-AWN-02-01
DRAWN: JCF

DATE: 23/08/13
ISSUE: A
SCALE: 1 : 3

BRICK VENEER CONSTRUCTION - HEAD & JAMB DETAIL

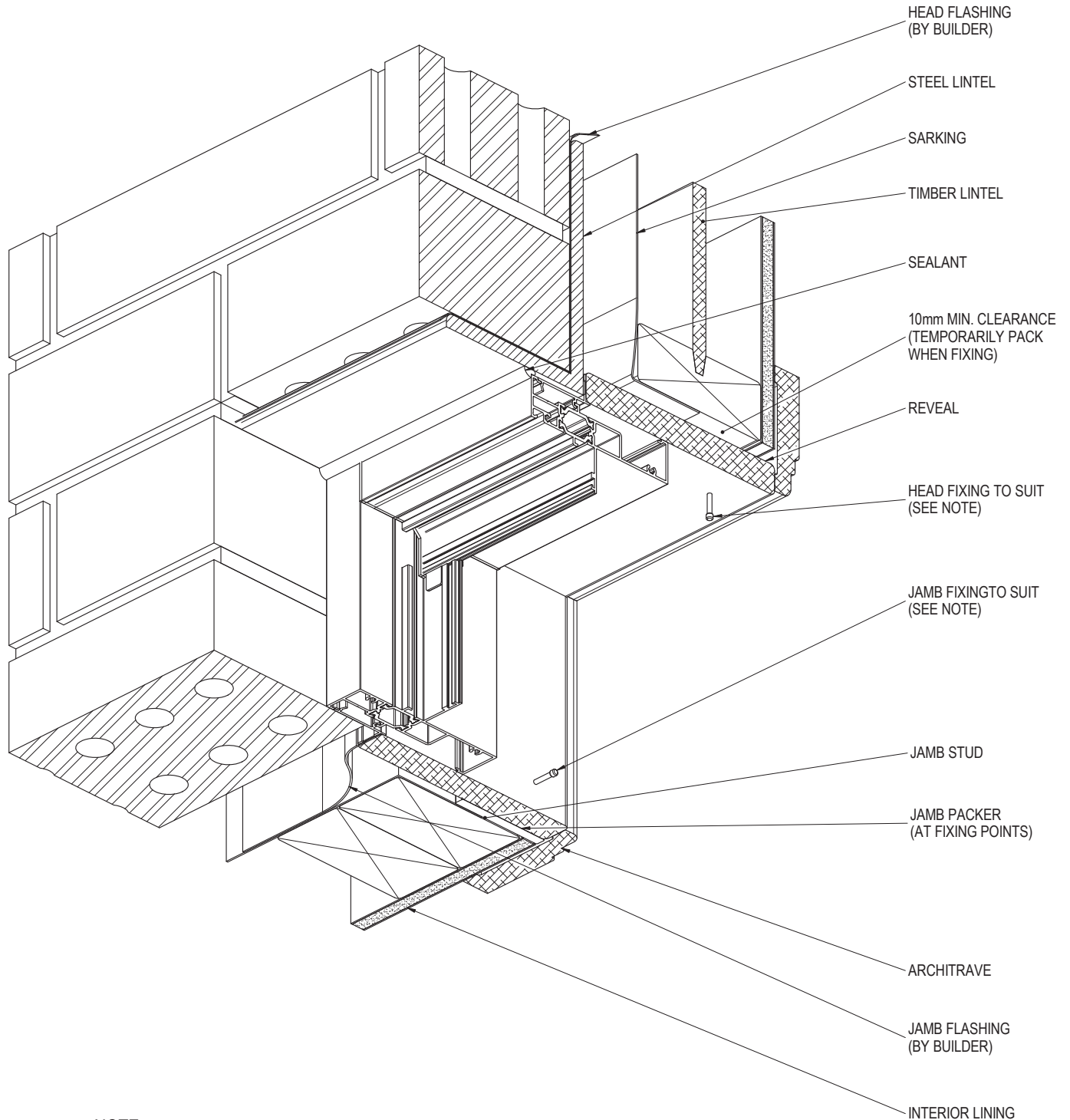

NOTE:
 FOR SITE CLASSIFICATIONS OF UP TO AND INCLUDING 'N6' OR SIMILAR, FIXINGS ARE TO BE AT 450mm CENTRE MAXIMUM, FOR SITUATIONS IN EXCESS OF THIS THE FIXINGS ARE TO BE AT 300mm CENTRES MAXIMUM. FIXING SIZE TO BE EQUIVALENT TO A \varnothing 2.2mm STEEL NAIL MINIMUM.

PRODUCT NO: TB-AWN-100
 DRAWING NO: TB-AWN-02-02
 DRAWN: JCF

DATE: 23/08/13
 ISSUE: A
 SCALE: 1 : 3



CLADDING CONSTRUCTION - SILL & JAMB DETAIL

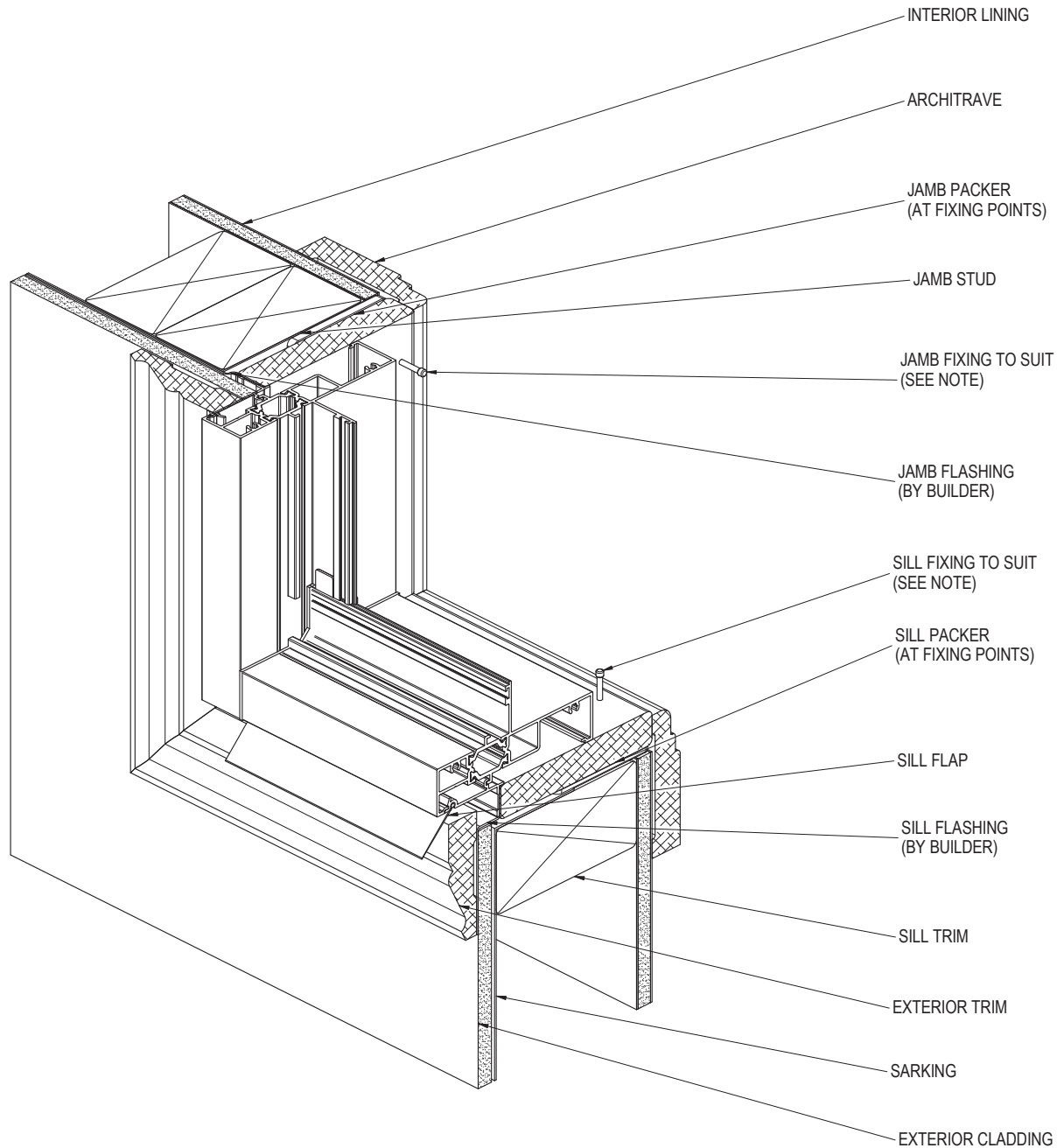

NOTE:
FOR SITE CLASSIFICATIONS OF UP TO AND INCLUDING 'N6' OR SIMILAR, FIXINGS ARE TO BE AT 450mm CENTRE MAXIMUM, FOR SITUATIONS IN EXCESS OF THIS THE FIXINGS ARE TO BE AT 300mm CENTRES MAXIMUM. FIXING SIZE TO BE EQUIVALENT TO A \varnothing 2.2mm STEEL NAIL MINIMUM.

PRODUCT NO: TB-AWN-100
DRAWING NO: TB-AWN-02-03
DRAWN: JCF

DATE: 23/08/13
ISSUE: A
SCALE: 1 : 3

 **SUNCOAST
WINDOWS**
Quality . Style . Innovation

CLADDING CONSTRUCTION - HEAD & JAMB DETAIL

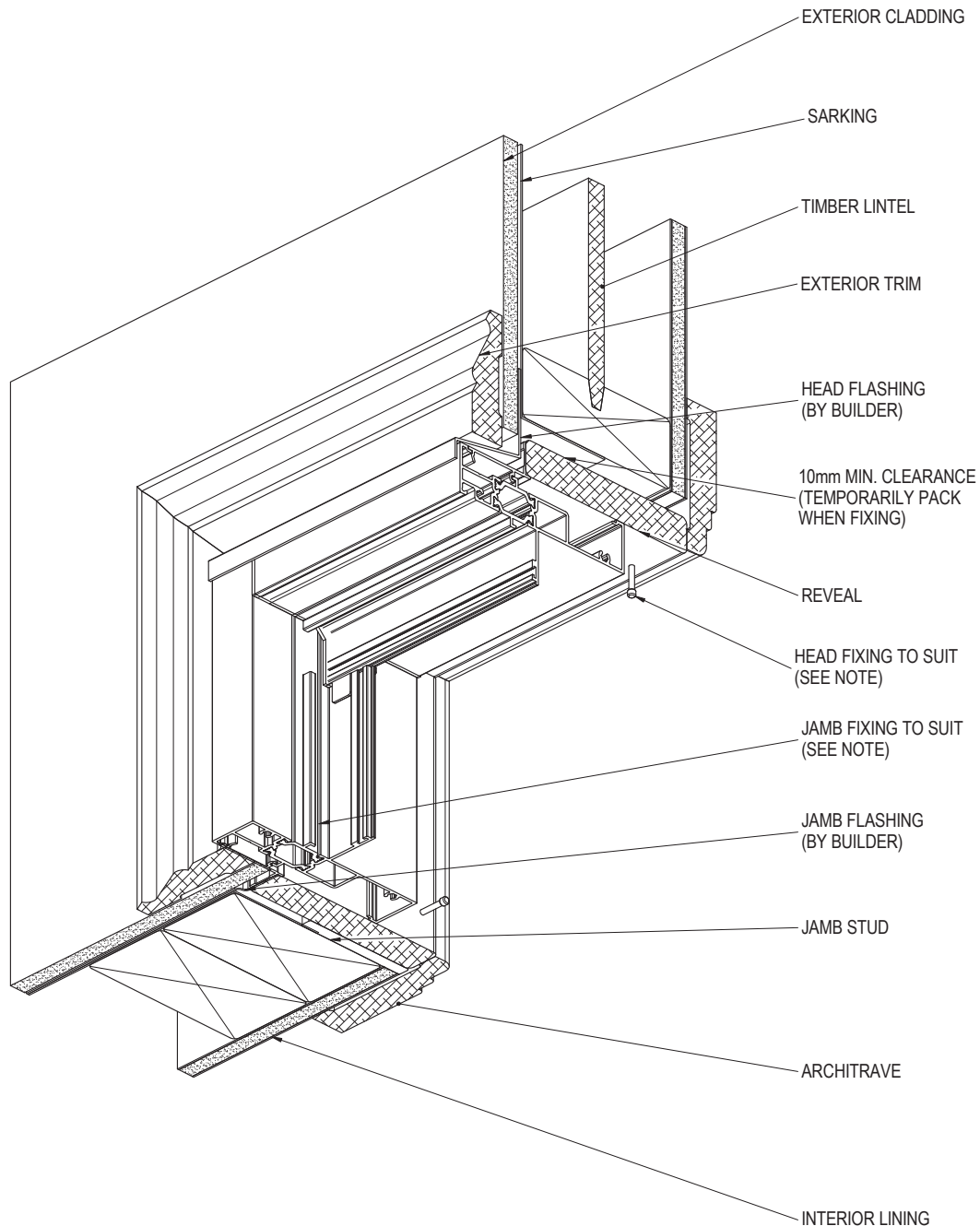

NOTE:
FOR SITE CLASSIFICATIONS OF UP TO AND INCLUDING 'N6' OR SIMILAR, FIXINGS ARE TO BE AT 450mm CENTRE MAXIMUM, FOR SITUATIONS IN EXCESS OF THIS THE FIXINGS ARE TO BE AT 300mm CENTRES MAXIMUM. FIXING SIZE TO BE EQUIVALENT TO A \varnothing 2.2mm STEEL NAIL MINIMUM.

PRODUCT NO: TB-AWN-100
DRAWING NO: TB-AWN-02-04
DRAWN: JCF

DATE: 23/08/13
ISSUE: A
SCALE: 1 : 3

 **SUNCOAST
WINDOWS**
Quality . Style . Innovation

CAVITY BRICK CONSTRUCTION - SILL & JAMB DETAIL

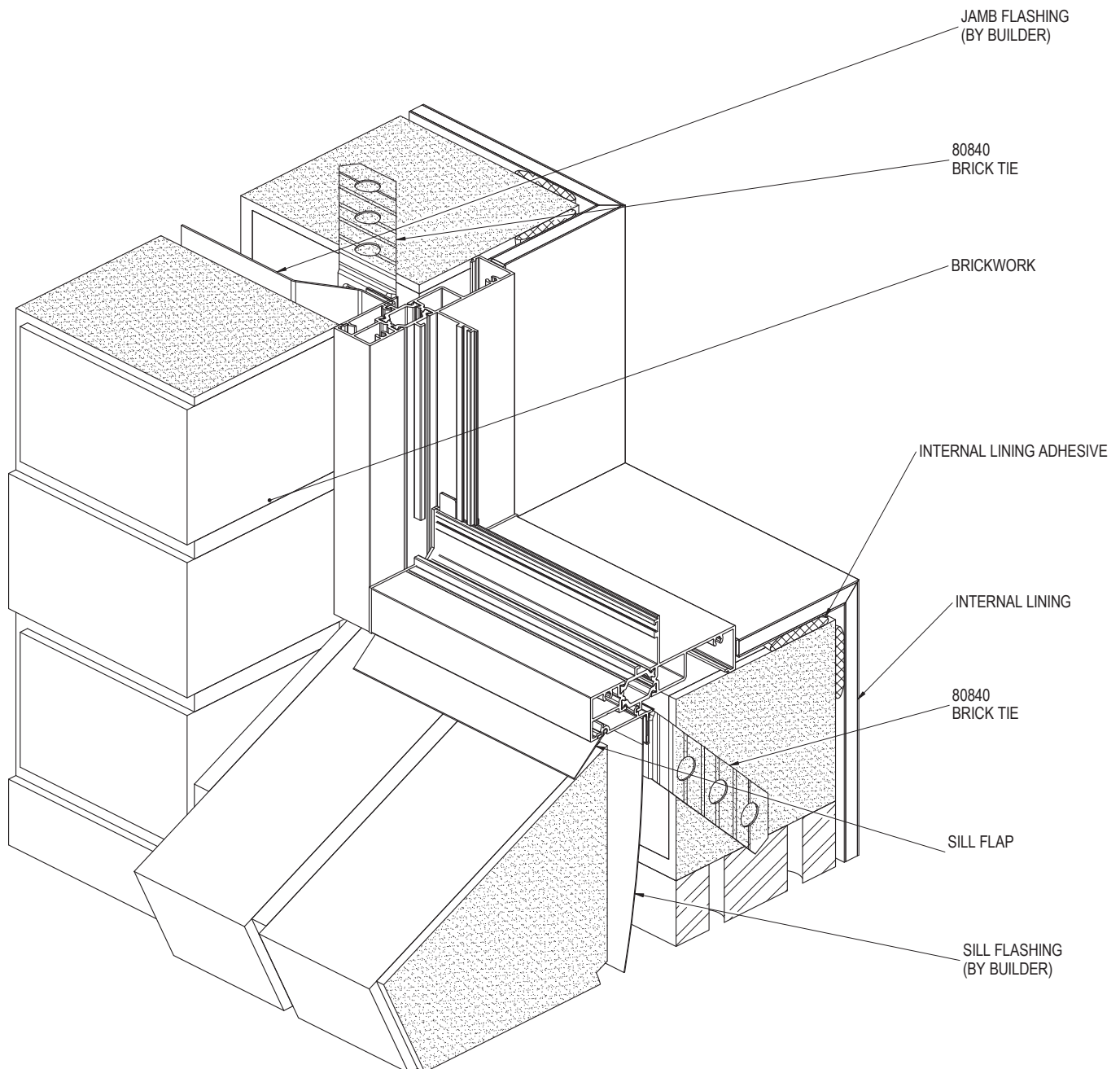

NOTE:
FOR SITE CLASSIFICATIONS OF UP TO AND INCLUDING 'N6' OR SIMILAR, FIXINGS ARE TO BE AT 450mm CENTRE MAXIMUM, FOR SITUATIONS IN EXCESS OF THIS THE FIXINGS ARE TO BE AT 300mm CENTRES MAXIMUM. FIXING SIZE TO BE EQUIVALENT TO A \varnothing 2.2mm STEEL NAIL MINIMUM.

PRODUCT NO: TB-AWN-100
DRAWING NO: TB-AWN-02-05
DRAWN: JCF

DATE: 26/08/13
ISSUE: A
SCALE: 1 : 3

 **SUNCOAST
WINDOWS**
Quality . Style . Innovation

CAVITY BRICK CONSTRUCTION - HEAD & JAMB DETAIL

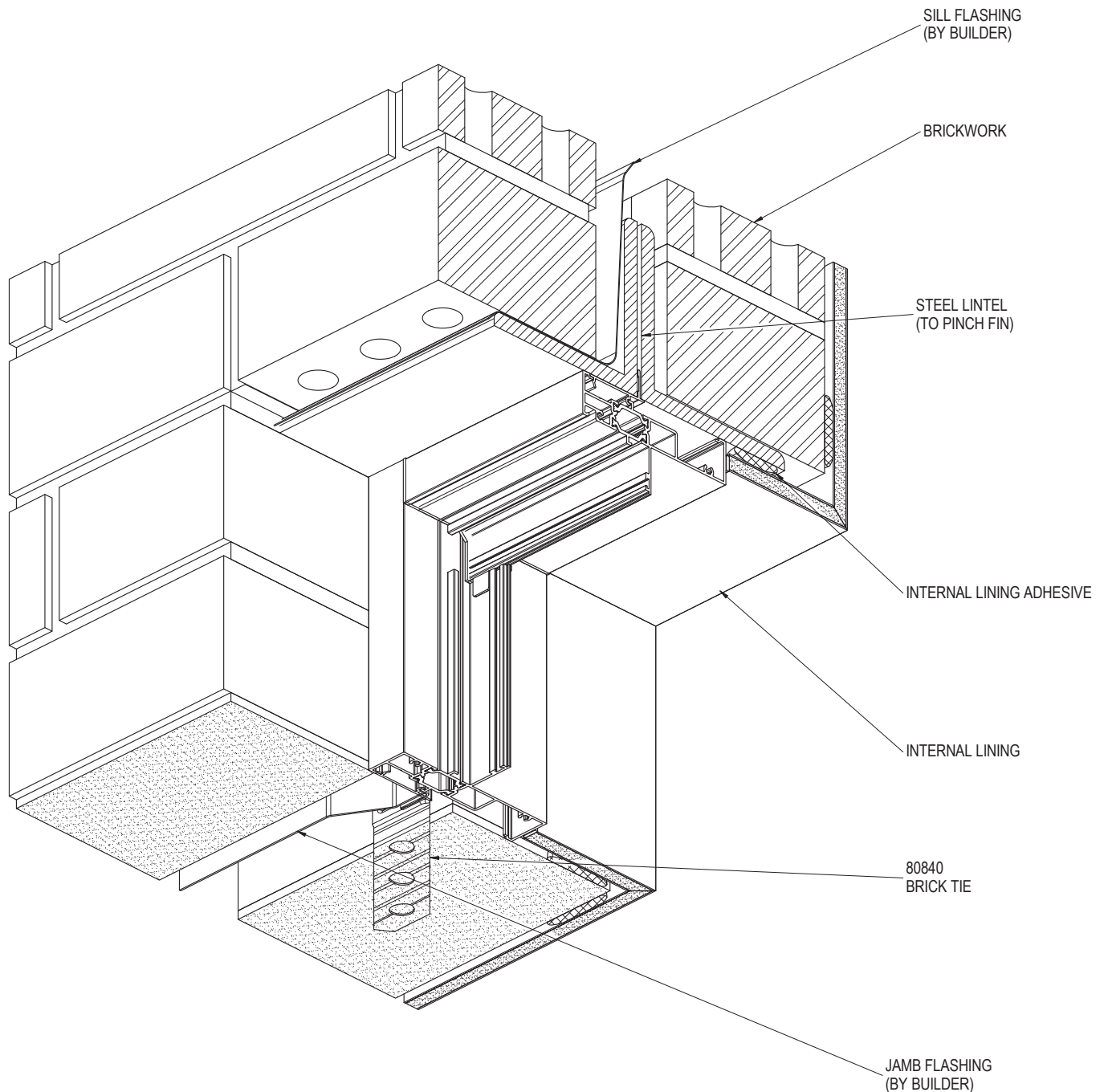

NOTE:
FOR SITE CLASSIFICATIONS OF UP TO AND INCLUDING 'N6' OR SIMILAR, FIXINGS ARE TO BE AT 450mm CENTRE MAXIMUM, FOR SITUATIONS IN EXCESS OF THIS THE FIXINGS ARE TO BE AT 300mm CENTRES MAXIMUM. FIXING SIZE TO BE EQUIVALENT TO A \varnothing 2.2mm STEEL NAIL MINIMUM.

PRODUCT NO: TB-AWN-100
DRAWING NO: TB-AWN-02-06
DRAWN: JCF

DATE: 26/08/13
ISSUE: A
SCALE: 1 : 3

 **SUNCOAST
WINDOWS**
Quality . Style . Innovation

BLOCKWORK CONSTRUCTION - SILL & JAMB DETAIL

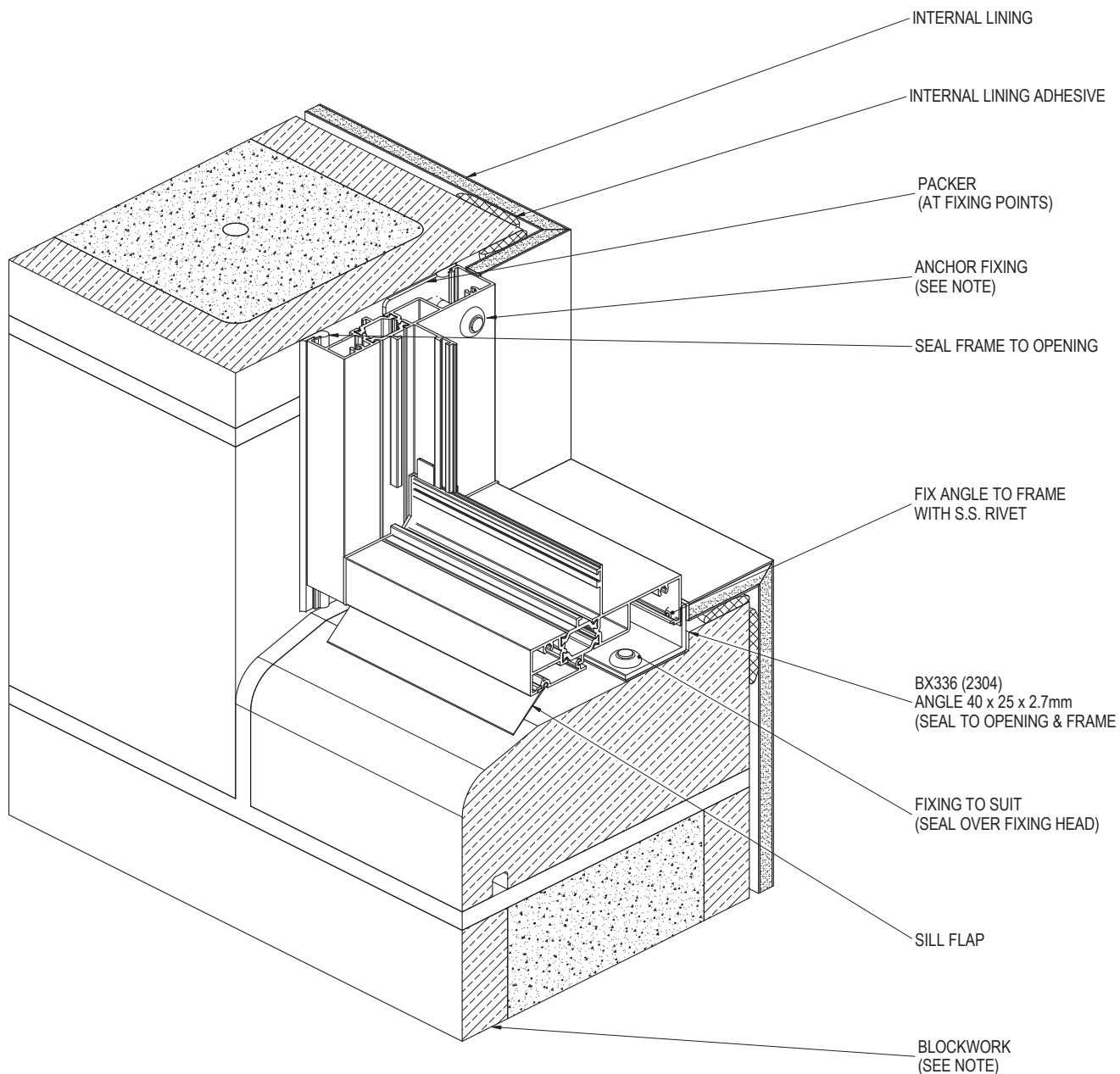

NOTE:
 SURFACE OF BLOCKS TO WINDOW OPENING MUST BE TANKED WITH A SUITABLE SEALER TO PREVENT INGRESS OF MOISTURE. ENSURE SURFACES TO BE SEALED ARE SOUND, CLEAN, DRY AND FREE FROM ANY CONTAMINANTS BEFORE SEALING.

FOR SITE CLASSIFICATIONS OF UP TO AND INCLUDING 'N6' OR SIMILAR, FIXINGS ARE TO BE AT 450mm CENTRE MAXIMUM, FOR SITUATIONS IN EXCESS OF THIS THE FIXINGS ARE TO BE AT 300mm CENTRES MAXIMUM. FIXING SIZE TO BE EQUIVALENT TO A ϕ 2.2mm STEEL NAIL MINIMUM.

PRODUCT NO: TB-AWN-100
 DRAWING NO: TB-AWN-02-07
 DRAWN: JCF

DATE: 26/08/13
 ISSUE: A
 SCALE: 1 : 3

BLOCKWORK CONSTRUCTION - HEAD & JAMB DETAIL

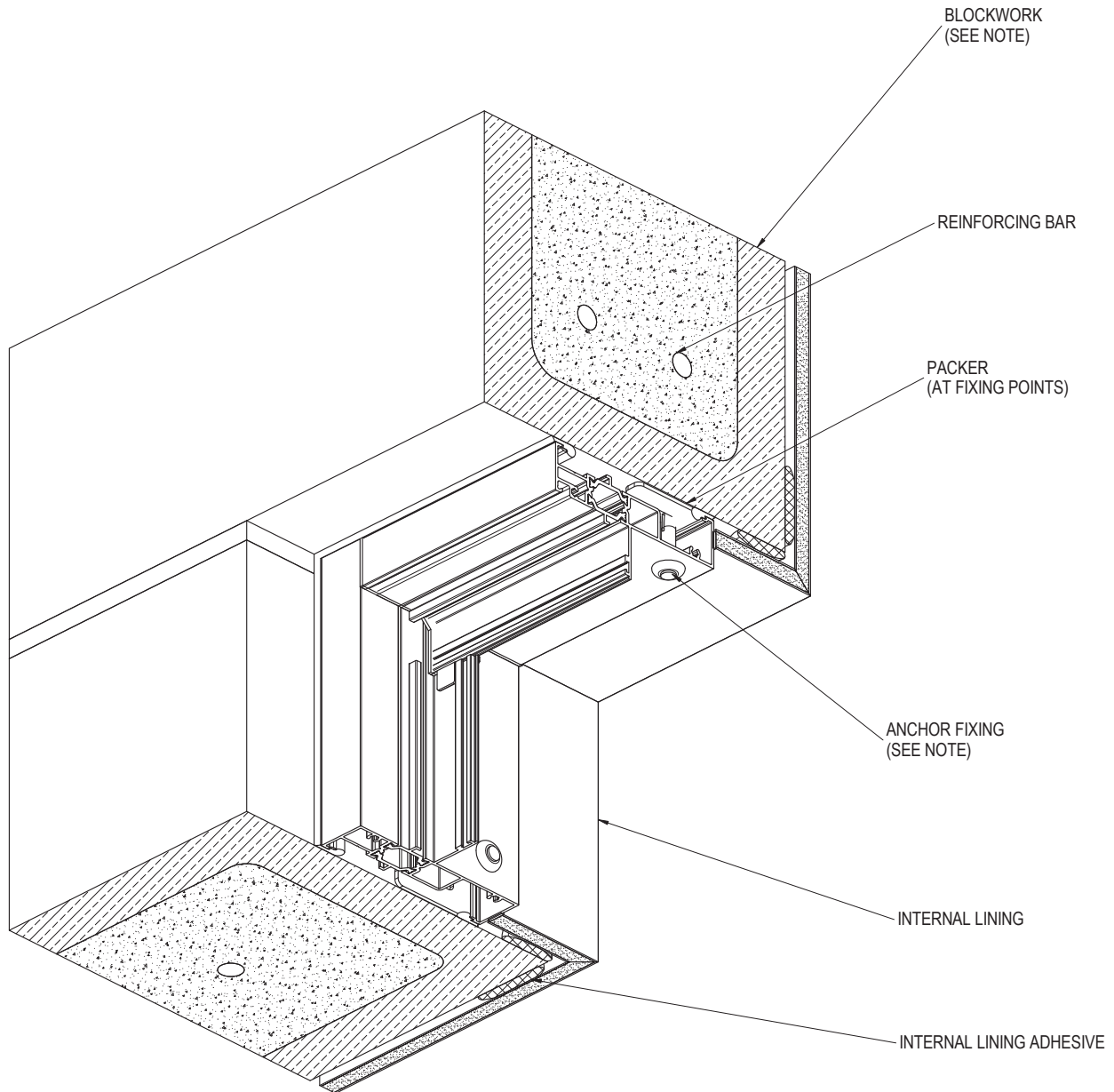

NOTE:

SURFACE OF BLOCKS TO WINDOW OPENING MUST BE TANKED WITH A SUITABLE SEALER TO PREVENT INGRESS OF MOISTURE. ENSURE SURFACES TO BE SEALED ARE SOUND, CLEAN, DRY AND FREE FROM ANY CONTAMINANTS BEFORE SEALING.

FOR SITE CLASSIFICATIONS OF UP TO AND INCLUDING 'N6' OR SIMILAR, FIXINGS ARE TO BE AT 450mm CENTRE MAXIMUM, FOR SITUATIONS IN EXCESS OF THIS THE FIXINGS ARE TO BE AT 300mm CENTRES MAXIMUM. FIXING SIZE TO BE EQUIVALENT TO A \varnothing 2.2mm STEEL NAIL MINIMUM.

PRODUCT NO: TB-AWN-100
DRAWING NO: TB-AWN-02-08
DRAWN: JCF

DATE: 26/08/13
ISSUE: A
SCALE: 1 : 3

 **SUNCOAST
WINDOWS**
Quality . Style . Innovation

TILT SLAB CONSTRUCTION - SILL & JAMB DETAIL

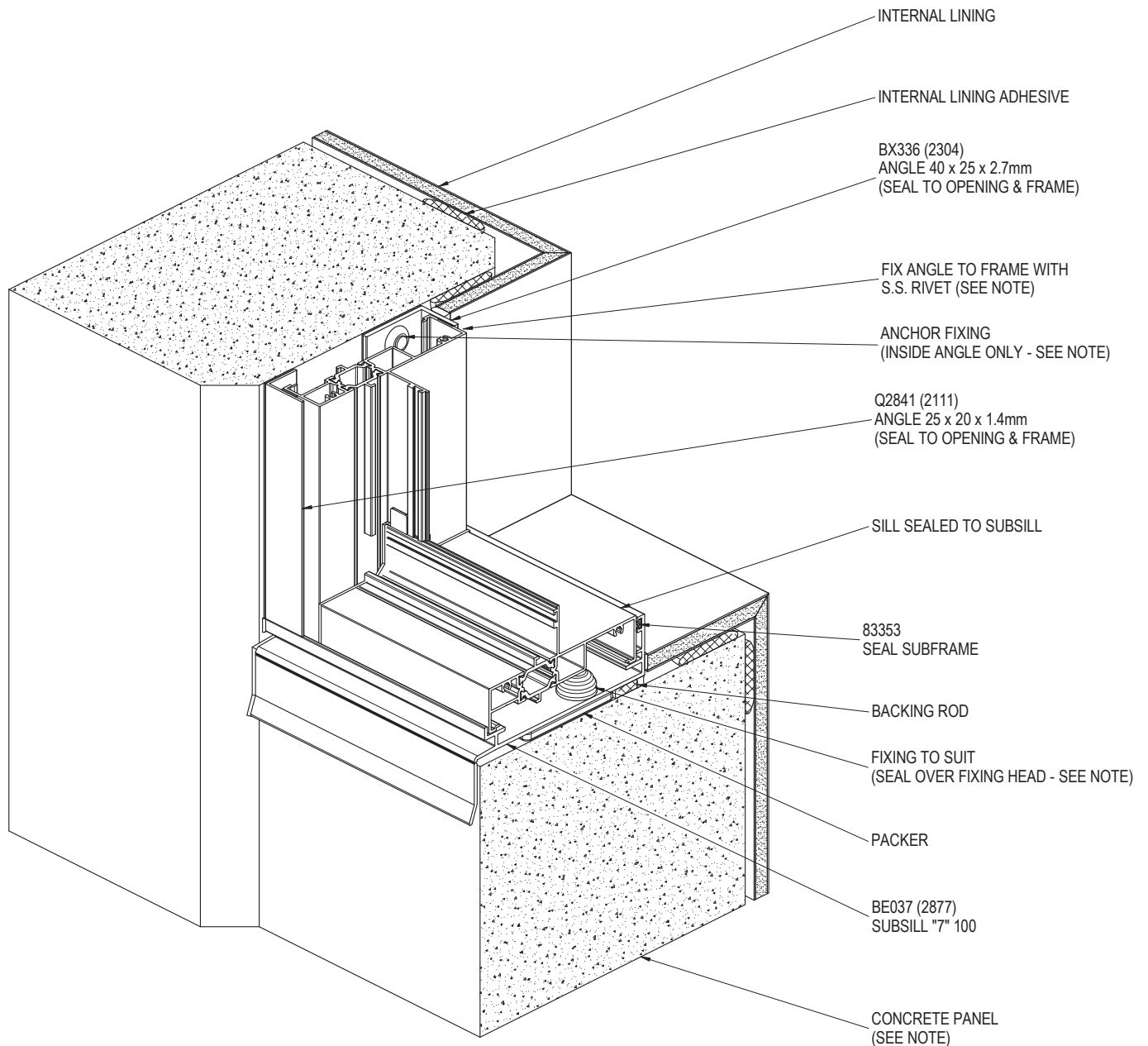

NOTE:
 SURFACE OF CONCRETE TO WINDOW OPENING MUST BE TANKED WITH A SUITABLE SEALER TO PREVENT INGRESS OF MOISTURE. ENSURE SURFACES TO BE SEALED ARE SOUND, CLEAN, DRY AND FREE FROM ANY CONTAMINANTS BEFORE SEALING.

FIXING TYPES & CENTRES TO BE PROJECT SPECIFIC, REFER TO SPECIFICATION AND/OR ENGINEER.

PRODUCT NO: TB-AWN-100
 DRAWING NO: TB-AWN-02-09
 DRAWN: JCF

DATE: 03/07/14
 ISSUE: A
 SCALE: 1 : 3



TILT SLAB CONSTRUCTION - HEAD & JAMB DETAIL

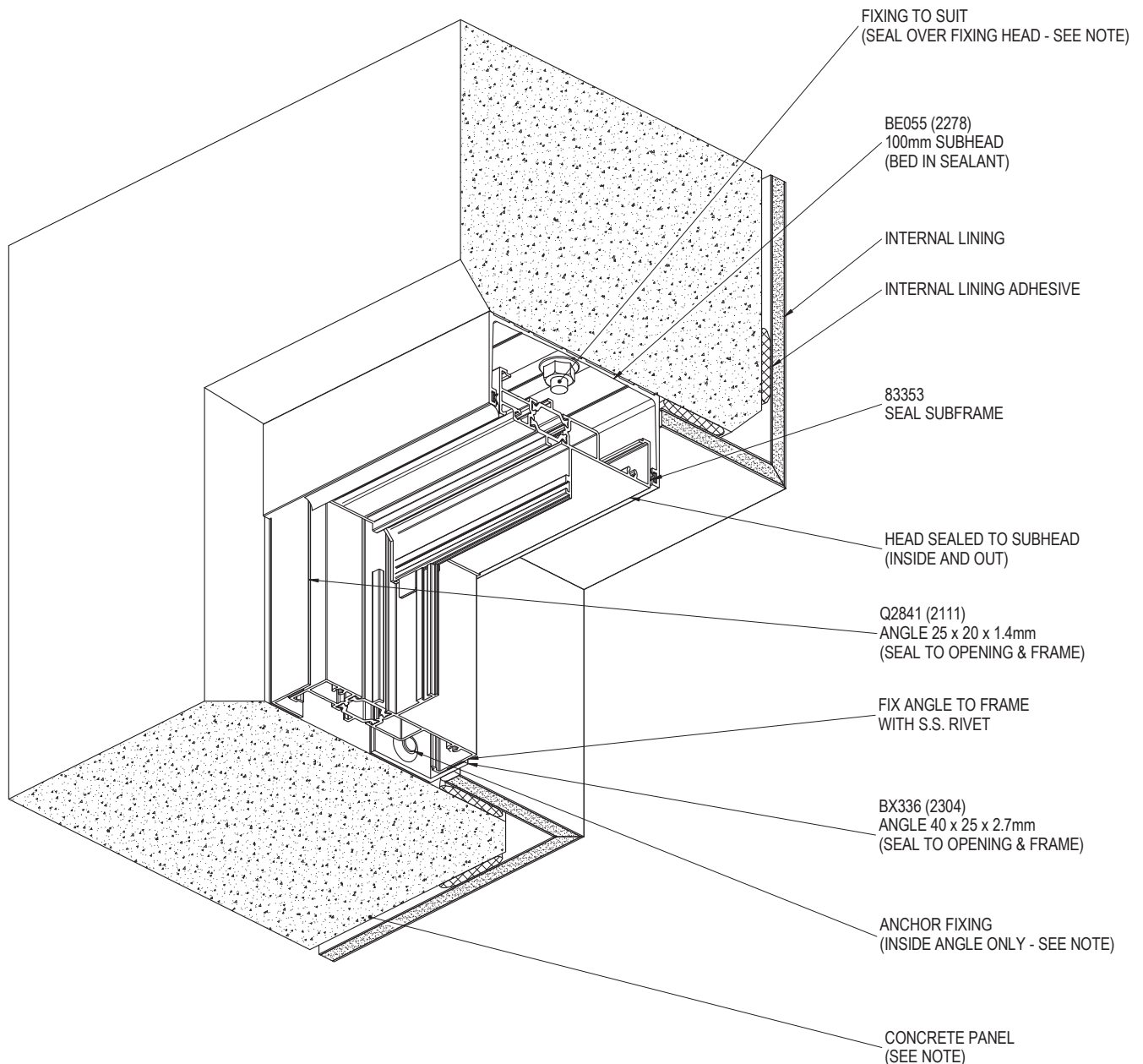

NOTE:
SURFACE OF CONCRETE TO WINDOW OPENING MUST BE TANKED WITH A SUITABLE SEALER TO PREVENT INGRESS OF MOISTURE. ENSURE SURFACES TO BE SEALED ARE SOUND, CLEAN, DRY AND FREE FROM ANY CONTAMINANTS BEFORE SEALING.

FIXING TYPES & CENTRES TO BE PROJECT SPECIFIC, REFER TO SPECIFICATION AND/OR ENGINEER.

PRODUCT NO: TB-AWN-100
DRAWING NO: TB-AWN-02-10
DRAWN: JCF

DATE: 03/07/14
ISSUE: A
SCALE: 1 : 3

 **SUNCOAST
WINDOWS**
Quality . Style . Innovation

SUBSILL DAM ANGLE INSTALLATION

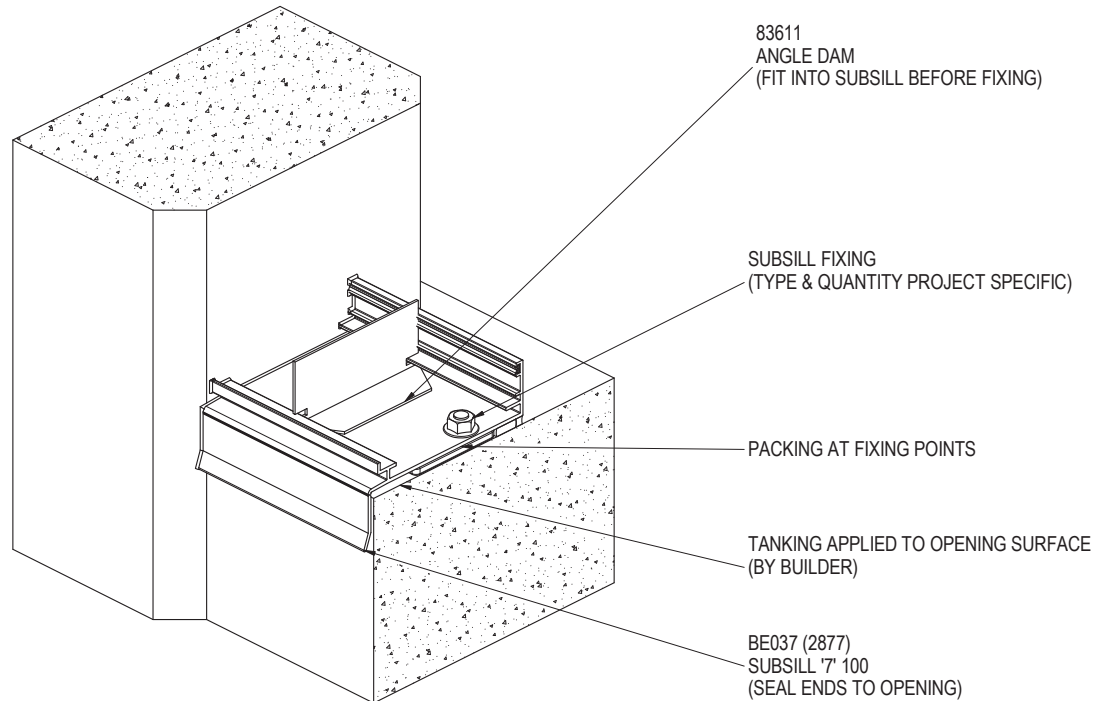

1. INSTALL SUBSILL INTO OPENING WITH DAM ANGLE FITTED. PACK SUBSILL LEVEL THEN FIX TO STRUCTURE. SEAL SUBSILL ENDS TO STRUCTURE.

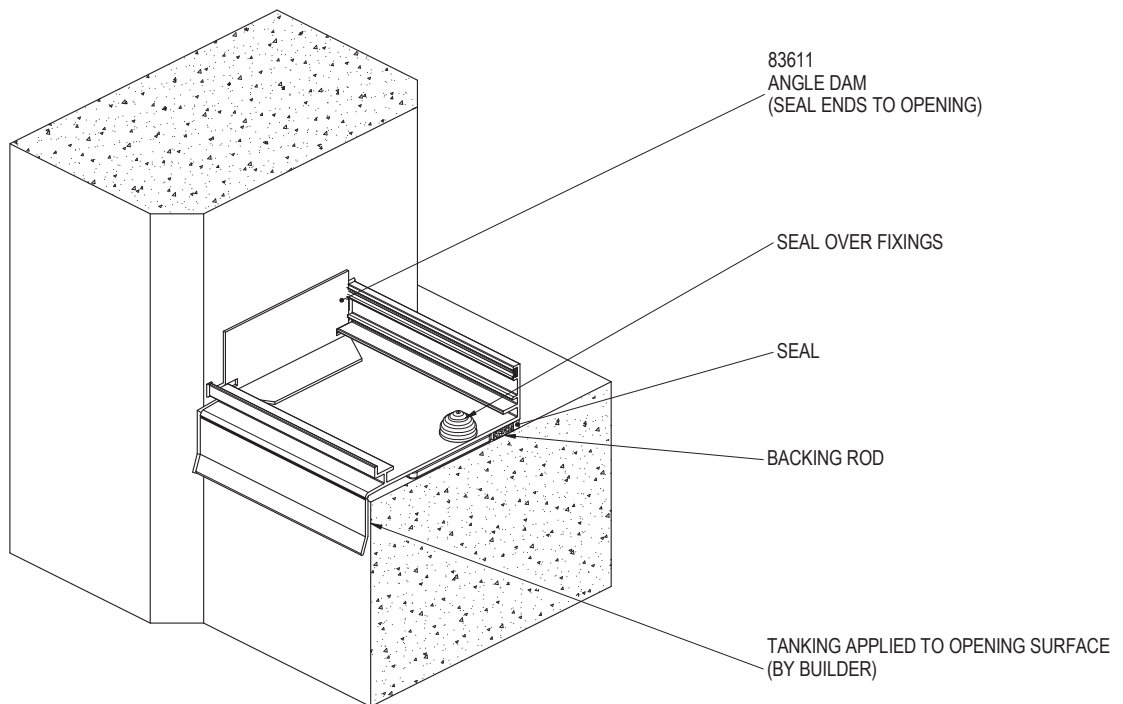

2. APPLY SEALANT TO VERTICAL FACE OF DAM ANGLE AND ALSO TO THE FLOOR OF THE SUBSILL. POSITION DAM ANGLE AGAINST THE STRUCTURE. SEAL ALL JOINTS BETWEEN THE ANGLE AND SUBSILL. SEAL ALL JOINTS BETWEEN ANGLE AND SUBSILL. SEAL OVER FIXINGS AND UNDER SUB SILL TO STRUCTURE.

PRODUCT NO: TB-AWN-100
DRAWING NO: TB-AWN-02-11
DRAWN: JCF

DATE: 03/07/14
ISSUE: A
SCALE: 1 : 3

 **SUNCOAST
WINDOWS**
Quality . Style . Innovation

SUBSILL DAM ANGLE INSTALLATION WITH FIXING & TRIM ANGLES

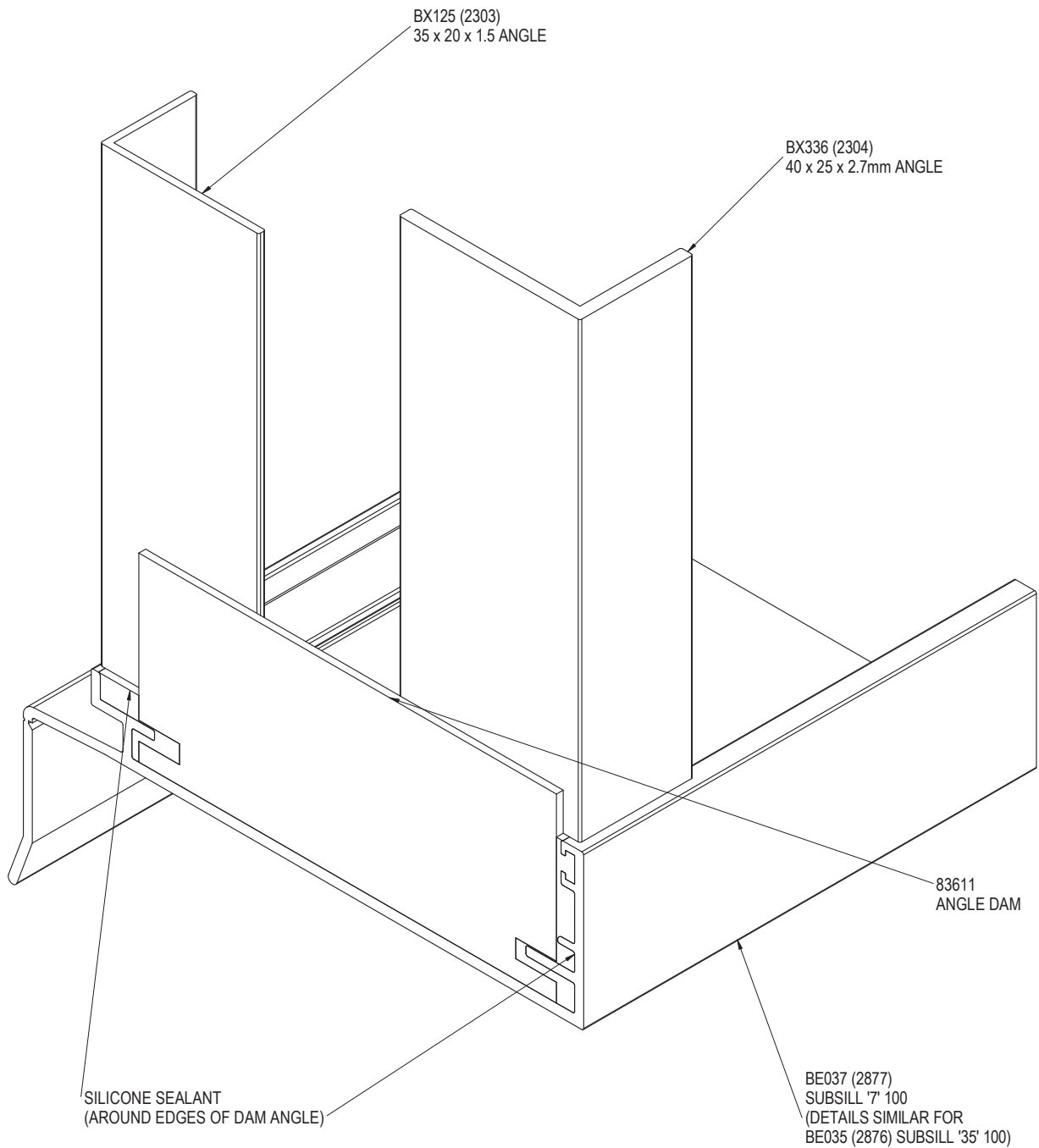

PRODUCT NO: TB-AWN-100
DRAWING NO: TB-AWN-02-12
DRAWN: JCF

DATE: 03/07/14
ISSUE: A
SCALE: 1 : 1